

Autodesk

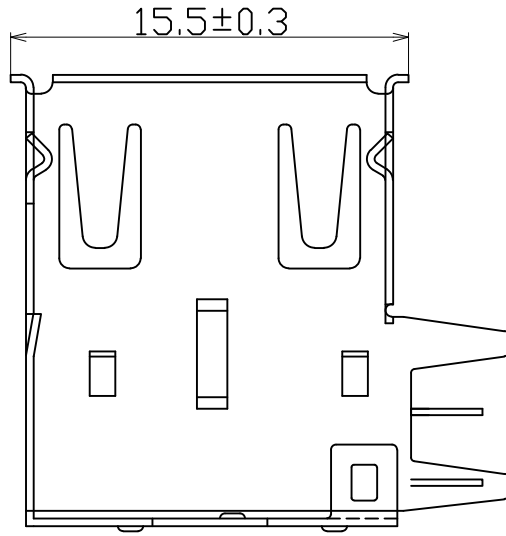
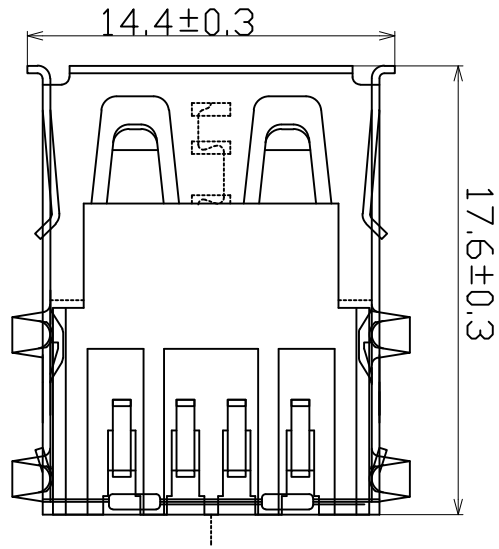

NOTE:

1.MATERIAL:

a.HOUSING:PBT GLASS FIBRE PBT

b.CONTACT:PHOSPHOR BRONZE T=0.25mm  
(SURFACE PLATING: Au1u" + Sn100u" + Ni60u")

c.SHEEL:BRASS T=0.30mm  
(SURFACE PLATING: Ni100u" ~ 120u")

2.ELECTRIC:

a.CONTACT RESISTANCE: 30 MILLIOHMS MAX

b.INSULATION RESISTANCE: 1000 MEGA OHMS MIN

c.DIELECTNIC VOLTAGE: 500V AC ONE SEC LEVEL

d.OPERATING TEMPERATURE: -55??- 105??

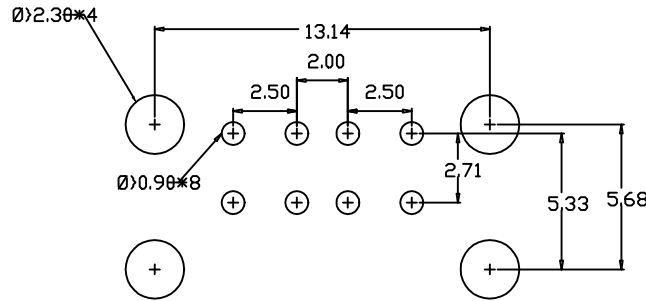
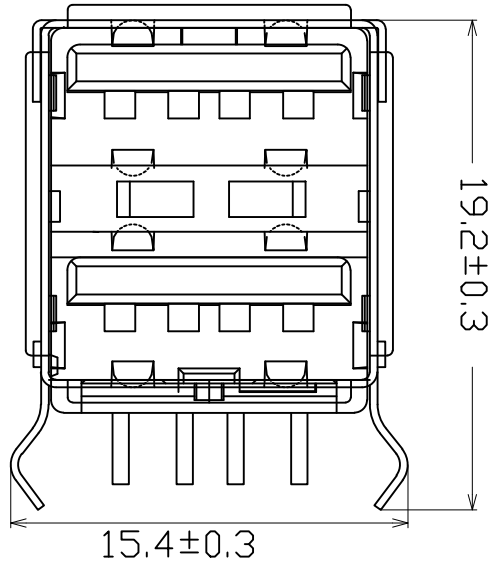

RBCOMMENDBD P. C. B PATTBRN LAY OUT

Autodesk

Autodesk

深圳市顺宏康科技有限公司

UNLESS OTHERWISE SPECIFIED TOLERANCE .X ±0.20 .XX ±0.15 .XXX ±0.10 ANG. ±2°	DRAWN H.Q.huocy		TITLE USB AF 双层半包有后盖双弹	REV. A	
	APPROVED		UNIT MM		PART NO. SHK-20119
	DATE 2011.03.18	SCALE 3/1	SIZE A4	DOC. NO.	

Autodesk