

REV.	ECN. NO.	APPD.
A	/	pcy

- Remark:
1. MATERIAL:
- 1.1 Housing:thermoplastic plastics.
 - 1.2 terminals:Copper Alloy
 - 1.3 Front Shell:Copper Alloy/SPCC.
Middle Shell:SPCC
2. characteristics:
- 2.1 Rating Voltage : 30V AC.
 - 2.2 Rating Current:PIN1&PIN4(Vbus&Corresponding ground PIN)
 - 2.3 Contact Resistance:PIN1&PIN4:30 mΩ MAX. Other PINS: 50 mΩ
 - 2.4 Insulation Resistance:100 MΩ MIN.
 - 2.5 Withstanding Voltage:AC 100V between adjacent contacts
 - 2.6 Mating force: 3.57Kgf MAX(35N MAX)
 - 2.7 Extraction force:1Kgf Min(9.8N Min)
 - 2.8 Life test:1500Cycles MIN.
 - 2.9 Temperature Range: -30℃~+80℃.

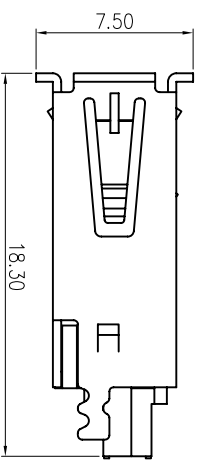
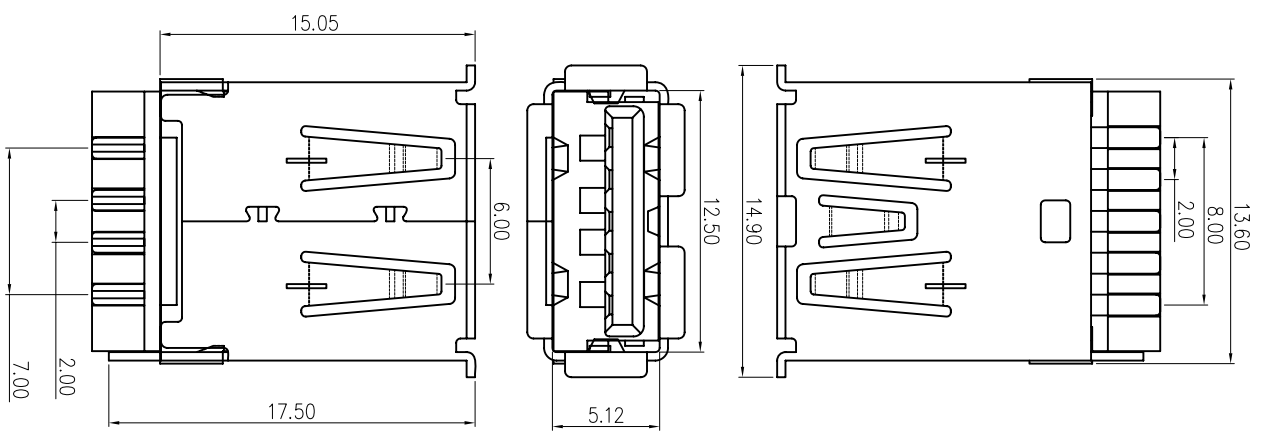

- U325-014X-XXX0XR
- 1:Iron alloy
 - Ni plating
 - 5:Copper alloy
 - Ni plating
 - 1: Au 1u"
 - 3: Au 3u"
 - 5: Au 5u"
 - 7: Au 10u"
 - 8: Au 15u"
 - A: Au 30u"
- 1: tray
 - 2: Tube
 - 8: Tape&Reel
 - 9: Tape&Reel+Mylar
 - 1: Black
 - 7: Blue 300C
 - 8: Blue 300C-1
 - C: Blue 300C-2
 - E: Blue 300C-3
 - 9: Carbon black425C
 - 1: PA66
 - 2: PBT
 - 6: LCP

深圳市顺宏康科技有限公司

TOLERANCE UNLESS OTHERWISE SPECIFIED	
.XXX ±0.10	.X° ±3°
.XX ±0.20	.XX° ±2°
.X ±0.30	

APPROVED: _____ PART NAME: USB 3.0 AF 焊线式

CHECKED: _____ PART No.: SHK-30137

DRAWN: pengchaoyong PROJECTION: _____ UNIT: mm SCALE: 1:1 SHEET: 1 OF 1 REV. A

DATE: 2014.09.29