

1	2	3	4	5	6	7	8
REV.	MODIFICATION	ECN No.	NAME	DATE			
A1	增加卡勾弹力,修改弹片加高0.2MM	2012061301	hu	2012-06-13			
A2	插拔易脱落增加凸点和两只固定脚, PCB增加两焊盘	2012072601	hu	2012-07-26			

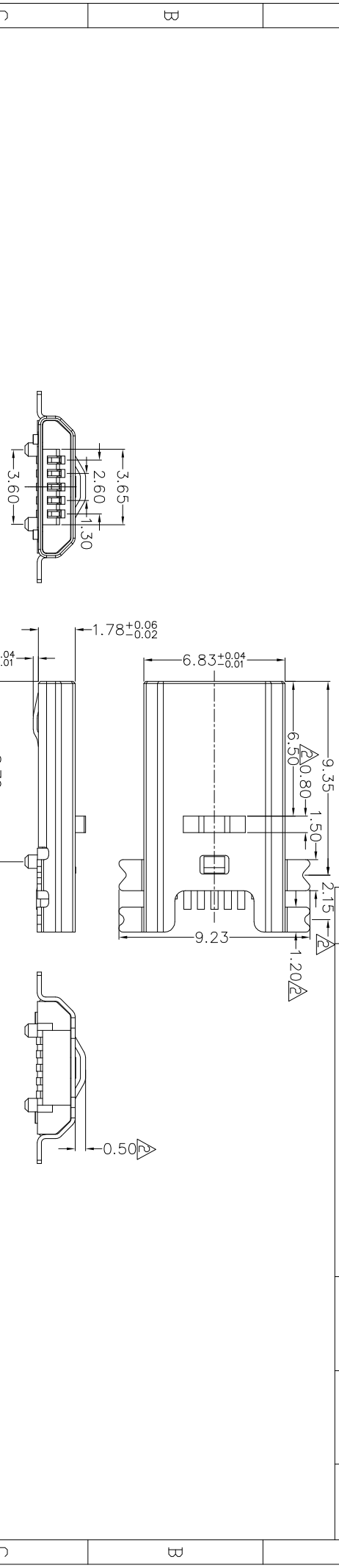

NOTE:

1. Electrical

- 1.1. Rated Voltage: 30V AC maximum
- 1.2. Rated Current: 1A min.
- 1.3. DIELECTRIC WITHSTANDING VOLTAGE: 100VAC, 1MIN
- 1.4. INSULATION RESISTANCE:
 - a, UNMATED: 100M OHMS MIN AT 500 VDC
 - b, MATED: 10M OHMS MIN AT 150 VDC
- 1.5. Contact Resistance: 30mΩ Max.

2. Mechanical

- 2.1. Mating Force Max: 3.70kgf max.
- 2.2. Removal Force Min: 1.0kgf min.
- 2.3. Durability: 0.81~2.05kgf after 10,000 cycles at 100±50 cycles per hour.
- 3. Ambient Temperature: -30° C To +80° C

BOM:

4	DC-005M14-04	外壳	SUS301, T=0.20±0.03	JHM12002	镀可焊镍	1
3	DC-005M14-03	前盖	LCP UL 94V-0	HSP12004	黑色	1
2	DC-005M14-02	胶心	LCP UL 94V-0	HSP12003	黑色	1
1	DC-005M14-01	PIN	C5191, T=0.20±0.02	JHM12001	镀前金后锡	5

客人料号: 100070013

RECOMMENDED PCB LAYOUT

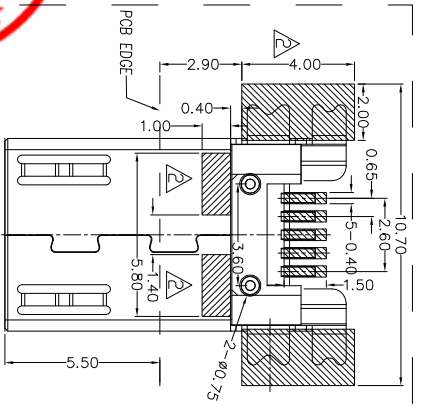

深圳市顺宏康科技有限公司

REV.: A/1	SCALE: FIT	PRODUCT NAME	micro usb 5P 贴板公头	核准
UNIT: mm	SHEET OF 1	零件名称		审核
GENERAL TOLERANCES		材料		制表
X. ±0.15	X°. ±2°	表面		日期
.X ±0.10	.X° ±0.5°	材质		Drawn by
.XX±0.05	.XX°±0.3°	表面		日期
THIRD ANGLE		表面		日期

1	料号	名称	材质	模号	数量
1	DC-005M14-01	PIN	C5191, T=0.20±0.02	JHM12001	5