

REV	LTR	DESCRIPTION	DATE	APPROVED
A0				

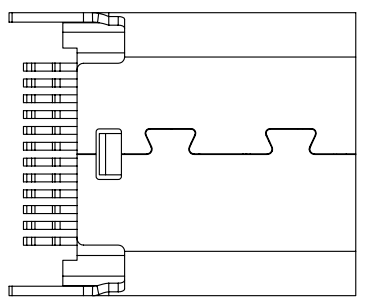
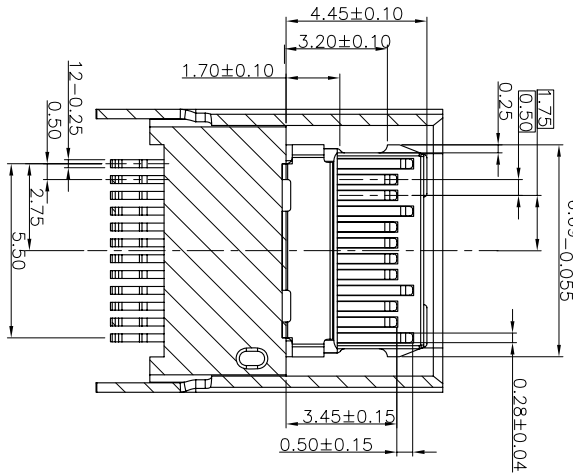
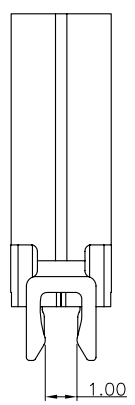
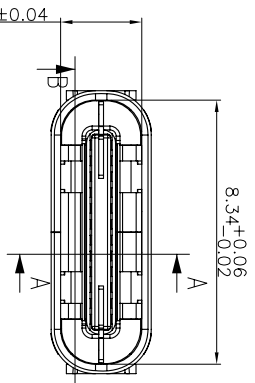
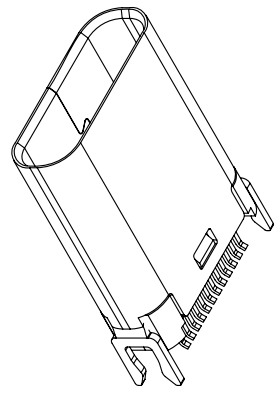
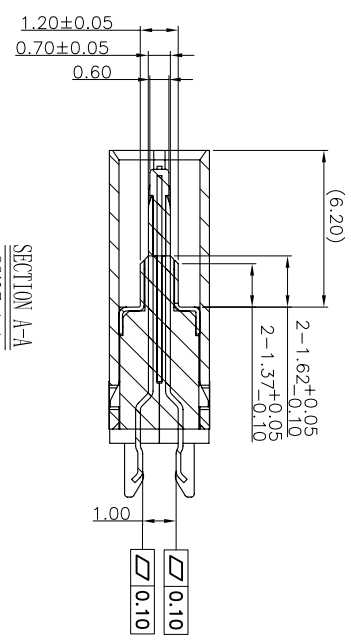
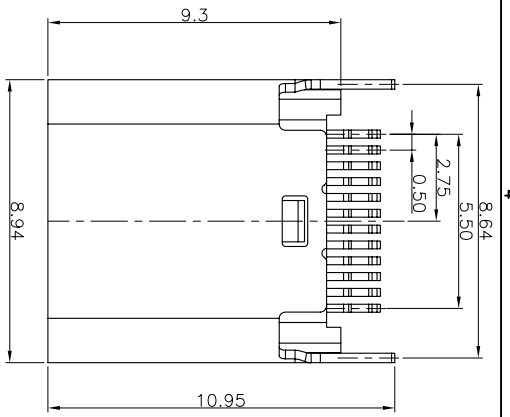

- NOTES:
- MATERIAL:
MOLDING: LCP UL94 V-0
CONTACT: COPPER ALLOY.
GOLD PLATED 30u" Min ON CONTACT AREA, 100u" Min TIN (LEAD FREE) ON SOLDER AREA, 50u" NICKEL PLATING OVER ALL.
SHELL: SUS304-H,T=0.30±0.03mm
SHILD: SUS304-H,T=0.12±0.03mm
 - MECHANICAL:
INSERTION: 5~20N.
EXTRACTION: 8~20N.
DURABILITY: 10000 CYCLES
 - ELECTRICAL:
CURRENT: 5A MIN FOR VBUS;
0.25A MIN FOR OTHER.
VOLTAGE: 5VAC MAX
WITHSTANDING VOLTAGE: 100V AC.
CONTACT RESISTANCE: 40mΩ MAX.
INSULATION RESISTANCE: 100MΩ MIN.
 - ENVIRONMENTAL
TEMPERATURE RANGE -55°C ~ +85°C

TOLERANCES	.X ±0.30
.XX ±0.20	
.XXX ±0.10	
ANGLES ±1.00°	
APPL.:	
PART NO.	SHK-31015C
TITLE:	USB 3.1Type-C/F 180夹板1.0 (9.30母座成品
APPD.:	
CHECK:	
DRAWN:	LTY
REV.:	A/0
SIZE:	A4
UNIT:	MM
SCALE:	1:1
SHEET:	1/1

深圳市顺宏康科技有限公司

