

REV.	ECN NO OR DESCRIPTION	REVISED	DATE
▽	PROPOSE ONLY	ALLEN	2015.12.04

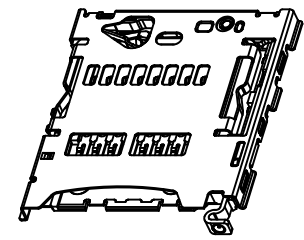
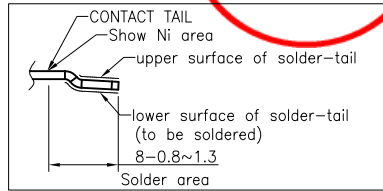
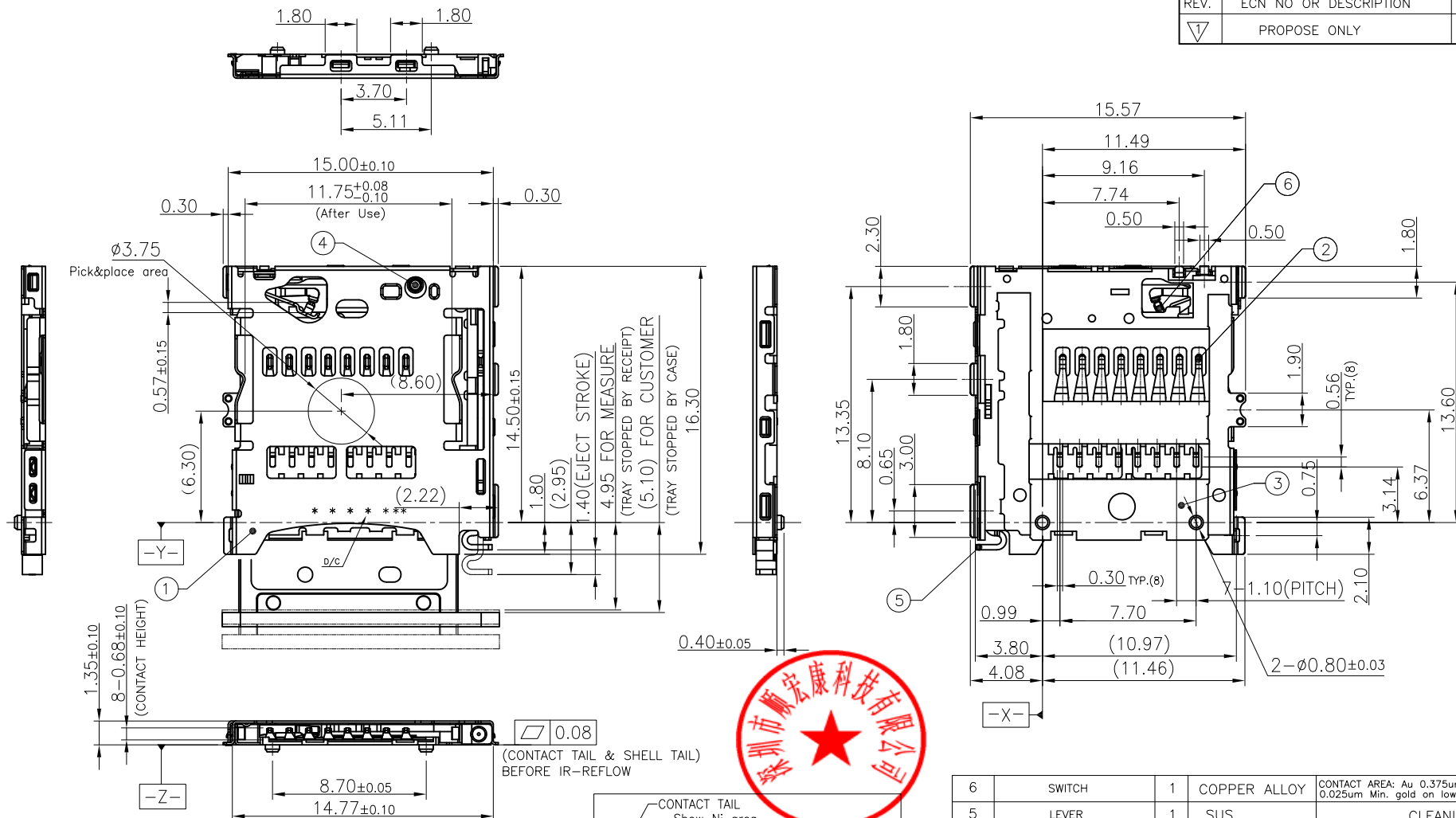

NOTES:

- ELECTRICAL REQUIREMENTS:
 - 1-1. CURRENT RATING : 0.5A PER PIN.
 - 1-2. CONTACT RESISTANCE : 50 mOhm MAX.
 - 1-3. INSULATION RESISTANCE : 1000 MOhm MIN.200 VDC FOR 1 MINUTE
 - 1-4. WITHSTANDING STRENGTH: 500V AC FOR 1 MINUTE.
- MECHANICAL CHARACTERISTICS:
 - 2-1. TRAY MATING FORCE: 15N MAX.; TRAY UNMATING FORCE: 3N MIN
 - 2-2. DURABILITY: 3000 CYCLES MIN.
- RECOMMENDED PROCESS DONDITION: IR-REFLOW, PEAK TEMPERATURE AND TIME: 250??5~10 S. BEFORE IR-REFLOW THE CO-PLANARITY 0.08MM MAX; AFTER 2 TIMES IR-REFLOW THE CO-PLANARITY 0.10MM MAX;
- Date code specification
 Year * * * * * V* version
 Month * * * * * Line No
 Day * * * * *
- (RECOMMEND METAL MASK):
THICKNESS IN CASE OF STENCIL IS 0.12MM. OPEN RATIO IS 100%.
- PLEASE CONTACT FOXCONN SALES REPRESENTATIVE TO VERIFY PRODUCT DETAILS & AVAILABILITY.

6	SWITCH	1	COPPER ALLOY	CONTACT AREA: Au 0.375um Min. 0.025um Min. gold on lower surface of solder-tail.
5	LEVER	1	SUS	CLEANING
4	CAM	1	SUS	CLEANING
3	I/M	1	LCP	BLACK COLOR UL94V-0
2	CONTACT	6	COPPER ALLOY	CONTACT AREA: Au 0.375um Min. 0.025um Min. gold on lower surface of solder-tail.
1	SHELL	1	SUS	CONTACT AREA: Au 0.375um Min. 0.025um Min. gold on lower surface of solder-tail.
ITEM	DESCRIPTION (P/N)	QTY	MATERIAL	FINISH

UNLESS OTHERWISE SPECIFIED TOLERANCES		深圳市顺宏康科技有限公司			
DECIMALS:	ANGLES:	TITLE	1.35H PIN PUSH T-Flash CARD CONN.(With Tray)		
X :±0.5	X :±2°	DWN	ALLEN	PART NO.	SHK-10359
X.X :±0.20	X.X :±1°	CHKD	KEVIN	SCALE:1:1	UNIT: mm
X.XX :±0.10		APVD	ERIC.W	SIZE: A3	SHEET:1OF 1
		REV: A1			
CUSTOMER COPY					

REV.	ECN NO OR DESCRIPTION	REVISED	DATE
▽	PROPOSE ONLY	ALLEN	2015.12.04

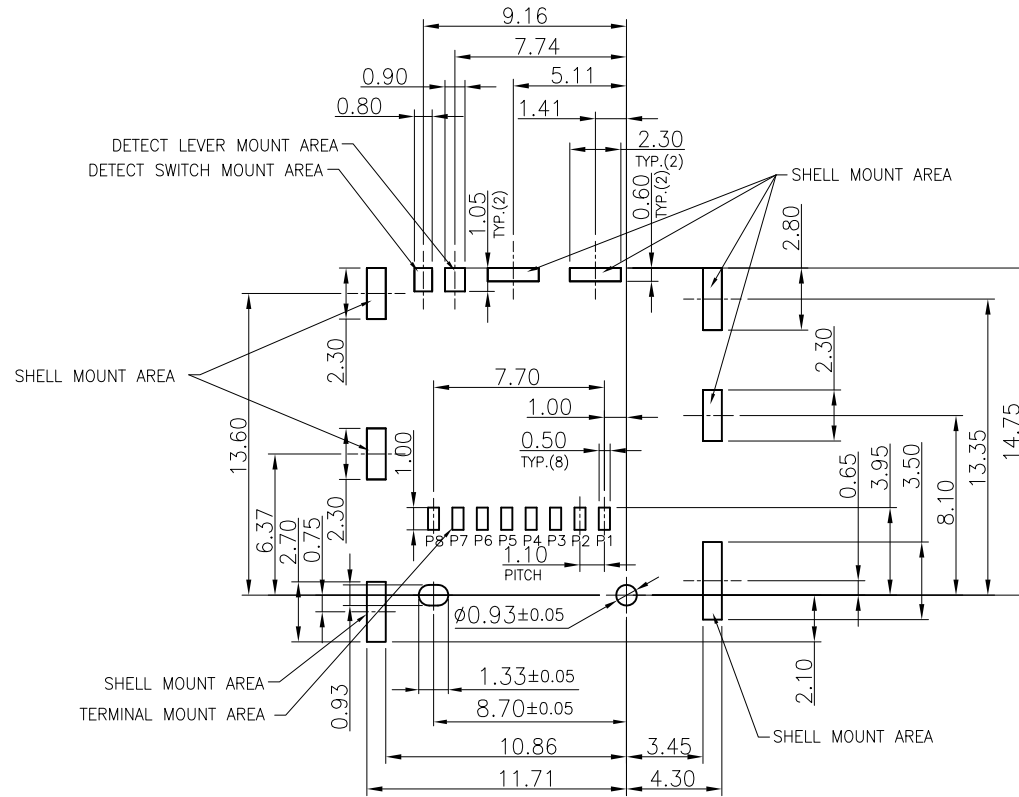

SUGGEST PCB THICKNESS 0.7MM MIN
TOLERANCE: +/-0.05

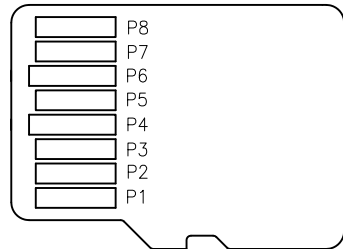

MSD CARD ELECTRICAL

CONNECTOR PIN ASSIGNMENT:

ITEM	FUNCTION
MICRO SD CARD	
P1	DAT2 OF MSD
P2	CD/DAT3 OF MSD
P3	CMD OF MSD
P4	VDD OF MSD
P5	CLK OF MSD
P6	VSS OF MSD
P7	DAT0 OF MSD
P8	DAT1 OF MSD
SC	SW CONTACT
SS	SW SPRING

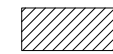
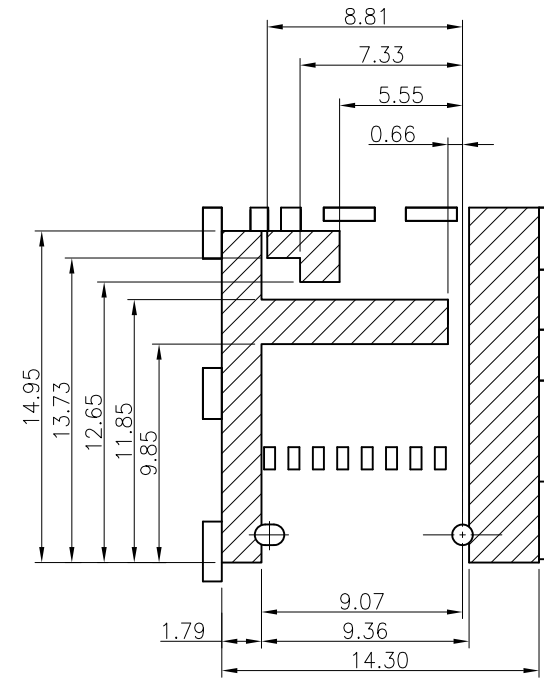

PATTERN KEEP OUT AREA
TOLERANCE: +/-0.05
GND RECOMMENDED PATTERN

CIRCUIT DIAGRAM FOR DETECT SWITCHES

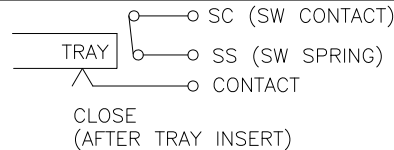
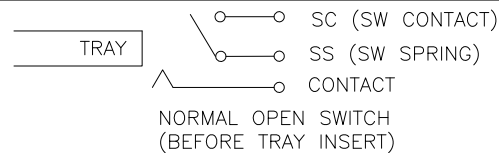

UNLESS OTHERWISE SPECIFIED TOLERANCES

DECIMALS:	ANGLES:
X :±0.5	X :±2°
X.X :±0.20	X.X :±1°
X.XX :±0.10	

深圳市顺宏康科技有限公司

TITLE	1.35H PIN PUSH T-Flash CARD CONN.(With Tray)			
DWN	ALLEN	PART NO.	SHK-10359	
CHKD	KEVIN	SCALE:1:1	UNIT: mm	
APVD	ERIC.W	SIZE: A3	SHEET:1OF 1	REV: A1

CUSTOMER COPY

REV.	ECN NO OR DESCRIPTION	REVISED	DATE
▽	PROPOSE ONLY	ALLEN	2015.12.04

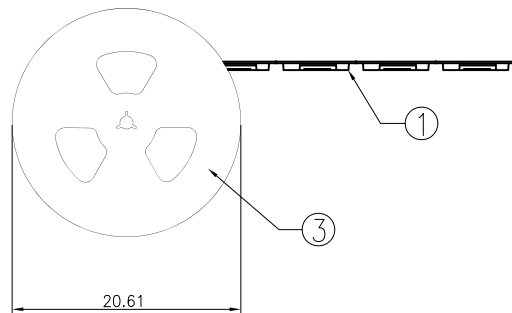
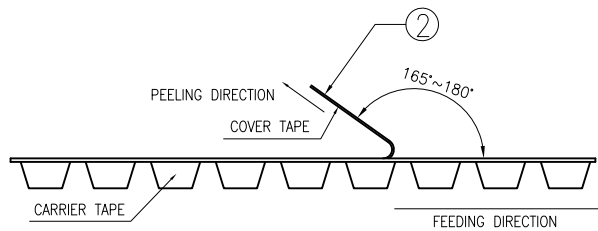
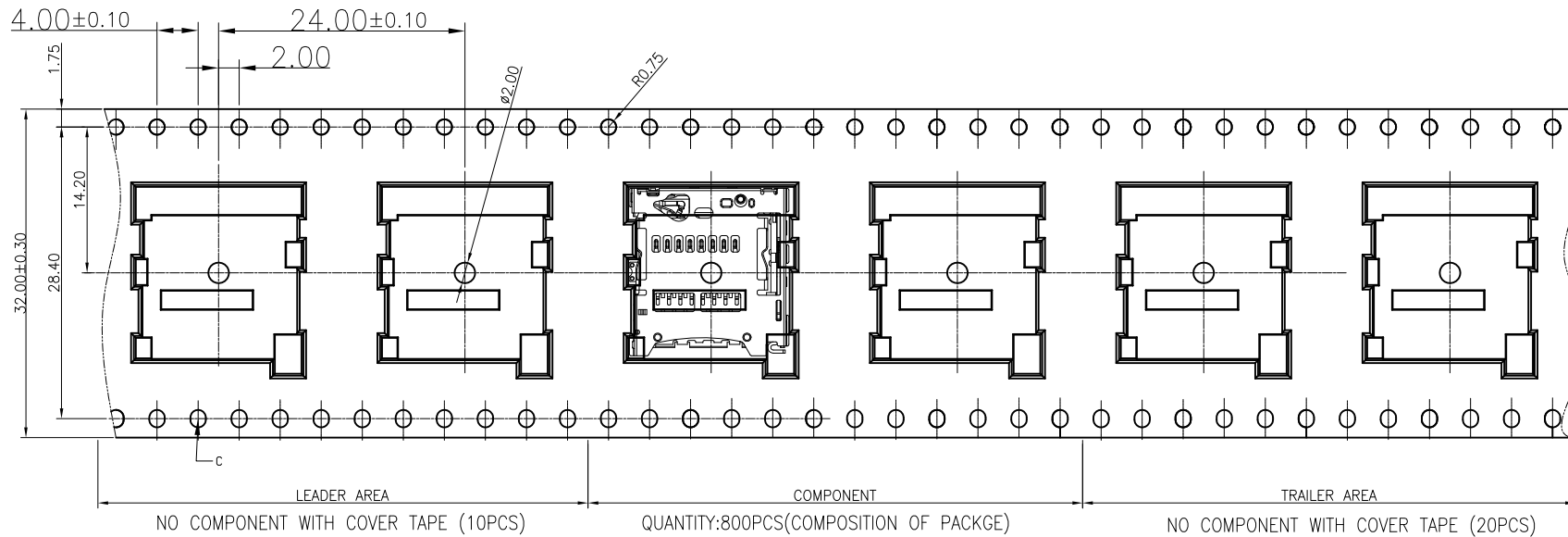

NOTES:

- 1, POCKET HOLE PITCH CLUMATIVE TOLERANCE $\pm 0.40\text{mm}$
- 2, Packaging capacity:
800pcs/REEL; 8REELI/CARTON ; TOTAL: 6400PCS/CARTON
- 3, Packaging Use Attention:
NOT TWISTED OVER 90° WITHIN 1000mm.

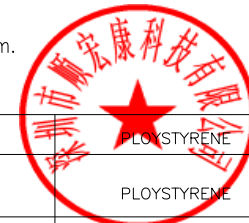

3	REEL	REEL	PLOYSTYRENE
2	COVER TAPE	COVER TAPE	PLOYSTYRENE
1	CARRIER TAPE	CARRIER TAPE	THERMOPLASTIC
ITEM	P/N	P/N	MATERIAL

UNLESS OTHERWISE SPECIFIED TOLERANCES		深圳市顺宏康科技有限公司			
DECIMALS:	ANGLES:	TITLE	1.35H PIN PUSH T-Flash CARD CONN.(With Tray)		
X :±0.5	X :±2°	DWN	ALLEN	PART NO.	SHK-10359
X.X :±0.20	X.X :±1°	CHKD	KEVIN	SCALE:1:1	UNIT: mm
X.XX :±0.10		APVD	ERIC.W	SIZE: A3	SHEET:1OF 1
		REV: A1			
CUSTOMER COPY					

REV.	ECN NO OR DESCRIPTION	REVISED	DATE
▽	PROPOSE ONLY	ALLEN	2015.12.04

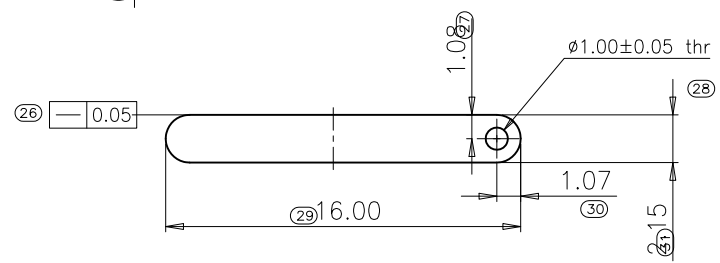
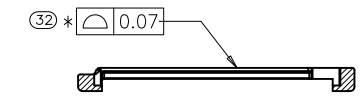
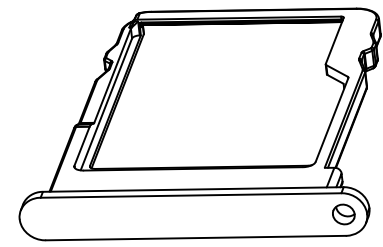
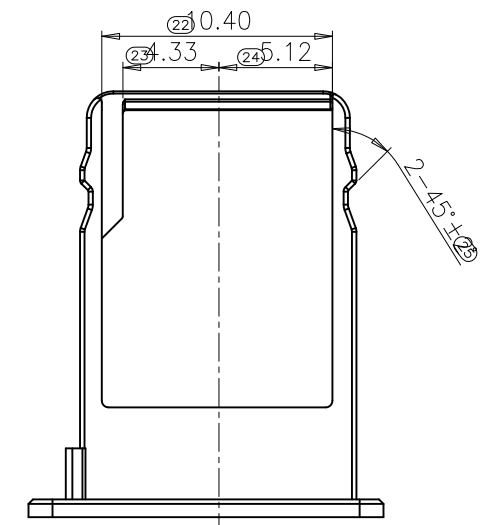
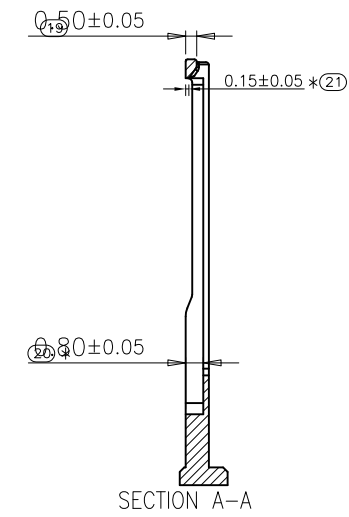
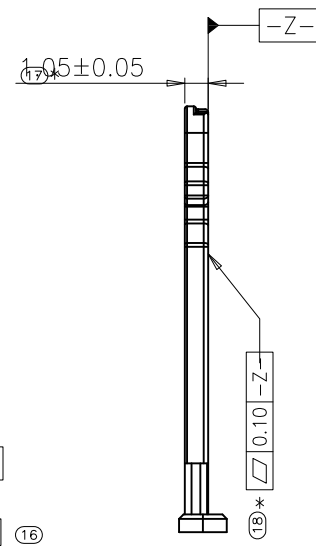
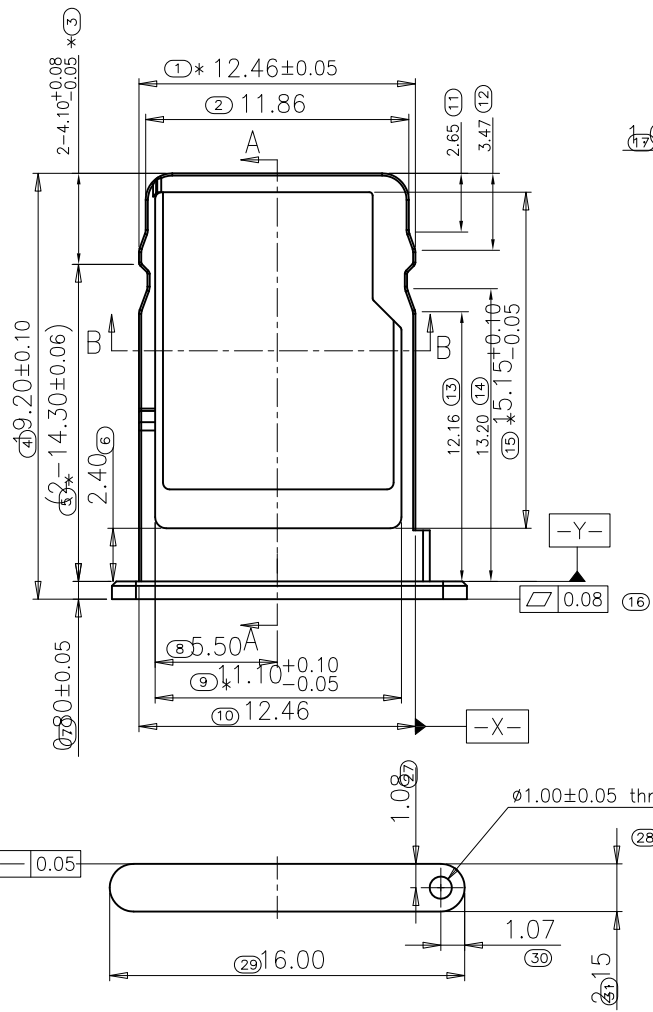

NOTES:

- 1.材料: 粉末冶金 17-4PH F.
- 2.外觀處理: 需參照ID工藝文件.
產品表面不得有鋒利邊, 毛刺, 壓痕, 劃傷, 油污, 多料, 缺料, 扭曲變形, 裂痕等缺陷.
- 3.尺寸: 2D圖面未標注公差尺寸, 其公差參照公差表; 未標注尺寸, 參照3D圖槽, 其公差參照公差表; 帶*尺寸為重點尺寸, 要求每批次檢驗; 帶▽尺寸需管控CPK, 且CPK ≥ 1.33;
未注工藝圓角, R ≤ 0.2mm; 未注同軸度0.1mm, 未注垂直度0.1mm;
未注拔模角度為1度或按0.05mm減膠拔模; 未注同軸度0.1mm, 未注垂直度0.1mm;
尺寸序號: 1~33.
- 4.產品需滿足(EU)WEEE和ROHS等認證要求; 在產品制程之原物料/
零件必須符合EPI12環境管理物質規定.



UNLESS OTHERWISE SPECIFIED TOLERANCES		深圳市順宏康科技有限公司			
DECIMALS:	ANGLES:	TITLE	1.35H PIN PUSH T-Flash CARD CONN.(With Tray)		
X :±0.5	X :±2°	DWN	ALLEN	PART NO.	SHK-10359
X.X :±0.20	X.X :±1°	CHKD	KEVIN	SCALE:1:1	UNIT: mm
X.XX :±0.10		APVD	ERIC.W	SIZE: A3	SHEET:1OF 1
		REV: A1			
CUSTOMER COPY					