

REV.	ECN NO OR DESCRIPTION	REVISED	DATE
1	PROPOSE ONLY	ALLEN	2017.06.23
2	修改端子为组装防溃 PIN	ALLEN	2018.01.12

SW Circuit Description for Connector:

CARD INSERTION STATE	DETECT SWITCH CIRCUIT STATE	SCHEMATIC
UNMATED	OPENED	DETECT PIN  C5
MATED	CLOSED	DETECT PIN  C5

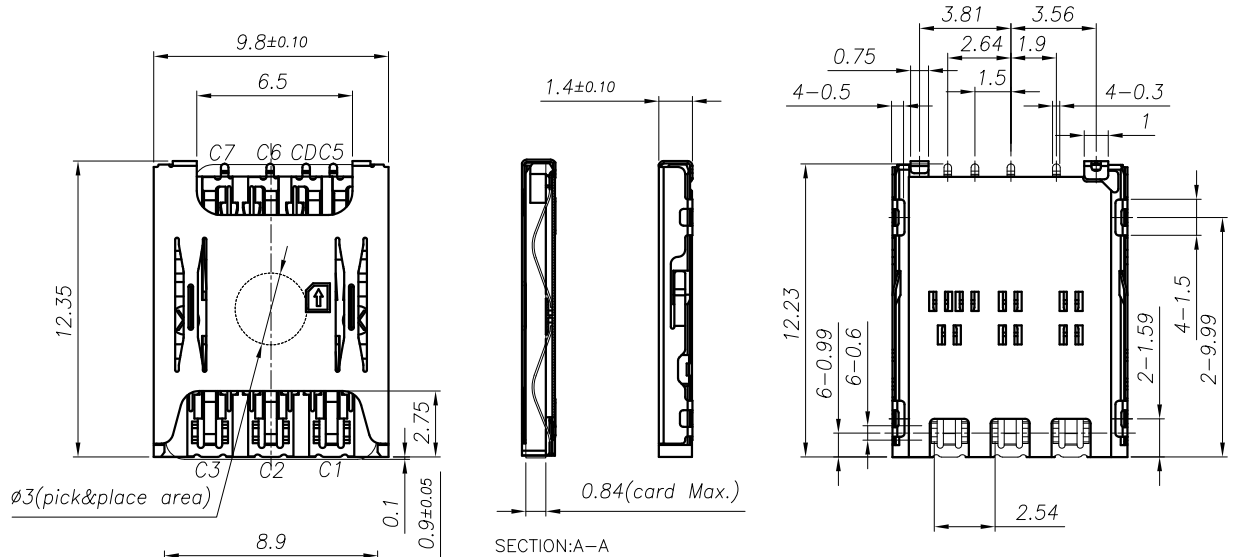

【 SIM Card Pin Assignments 】

PIN	Name
C1	Vcc
C2	RST
C3	CLK
C4	Reserved
C5	GND
C6	Vpp
C7	I/O
C8	Reserved

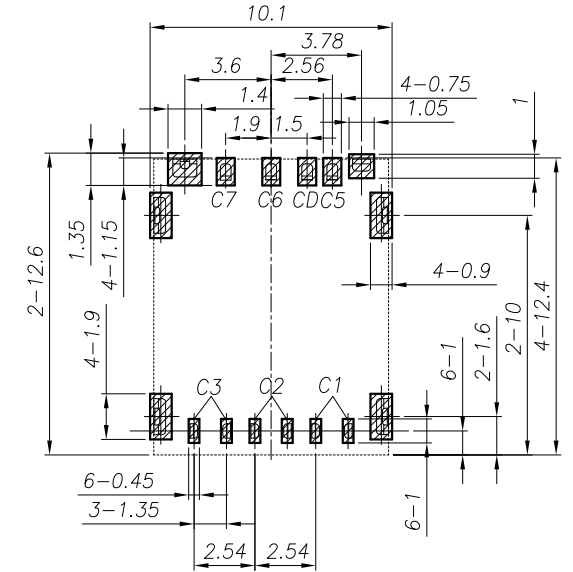
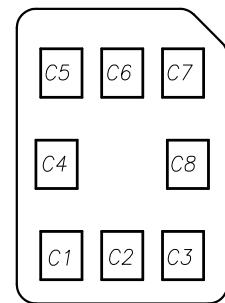

RECOMMENDED PCB LAYOUT TOP VIEW (TOLERANCE:±0.05)  
RECOMMENDED METAL MASK T=0.12MM

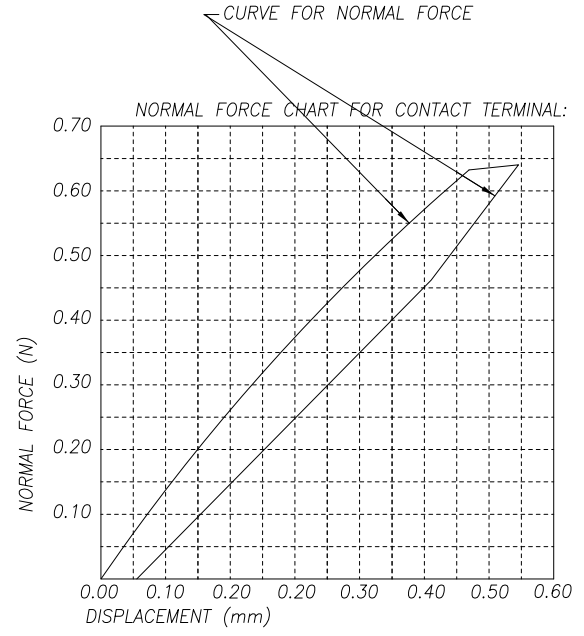
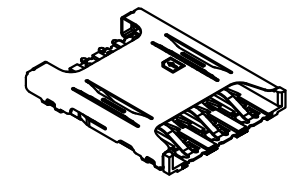

- NOTES:
- MATERIAL:SEE TABLE
  - SPECIALITY:
    - 2.1 Rated current: 0.5A Max
    - 2.2 Rated voltage: 30V AC
    - 2.3 Contact Resistance:100mohm MAX
    - 2.4 Insulation Resistance:1000Mohm MIN 500V DC
    - 2.5 Dielectric withstanding voltage: 500V AC/minute
    - 2.6 Solder ability:250±5 10±0.5s.
    - 2.7 Durability:5000 Cycles
    - 2.8 Mating and Unmating force  
Insertion Force 10N Max  
Withdrawal Fore 0.5N Min

3. PART No.:

NS 0 DD - 14 00 06- 10 G

Nano SIM CON. ] G=Gold Plating  
 0=WITHOUT POST ] 30=Product Order  
 DD=WITH UPLOCK ] Pin NO. 6=6Pin  
 14:HEIGHT 1.4mm ] 00=NORMAL TYPE.(ON PCB)



NO.	PART NAME	Q'TY	DESCRIPTION	NOTE
①	TERMINAL	6	C5210-EH,T=0.12	Au 5u" PLATING
②	BASE INSULATOR	1	LCP+GF30%	BLACK
③	SHELL	1	SUS304-H,T=0.12	AU/Ni PLATING

UNLESS OTHERWISE SPECIFIED TOLERANCES		深圳市顺宏康科技有限公司			
DECIMALS:	ANGLES:	TITLE	6Pin 1.4H PUSH PULL Nano SIM CARD CONN.		
X :±0.5	X :±2°	DWN	ALLEN	PART NO. SHK-10381	
X.X :±0.20	X.X :±1°	CHKD	KEVIN	SCALE:1:1	UNIT: mm
X.XX :±0.10		APVD	ERIC.W	SIZE: A3	SHEET:1OF 1
CUSTOMER COPY					
				REV: A2	

REV.	ECN NO OR DESCRIPTION	REVISED	DATE
▽	PROPOSE ONLY	ALLEN	2017.06.23

NOTES

1. NUMBER OF CONNECTORS: 1800PCS/REEL
2. LEAD TAPE LENGTH

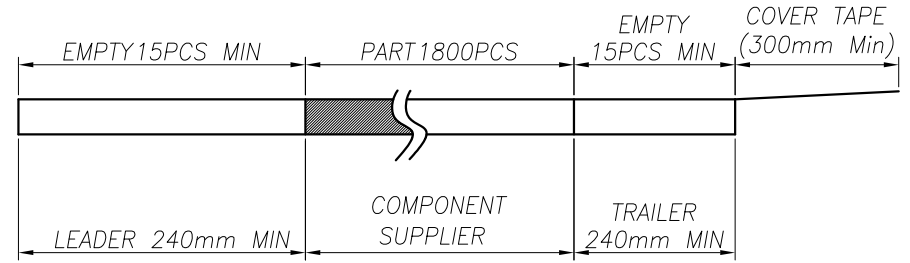

3. QUANTITY: 14400PCS/CARTON
4. WEIGHT :
  - 3.1 NET WEIGHT : 2.4Kg
  - 3.2 GROSS WEIGHT : 6.5Kg

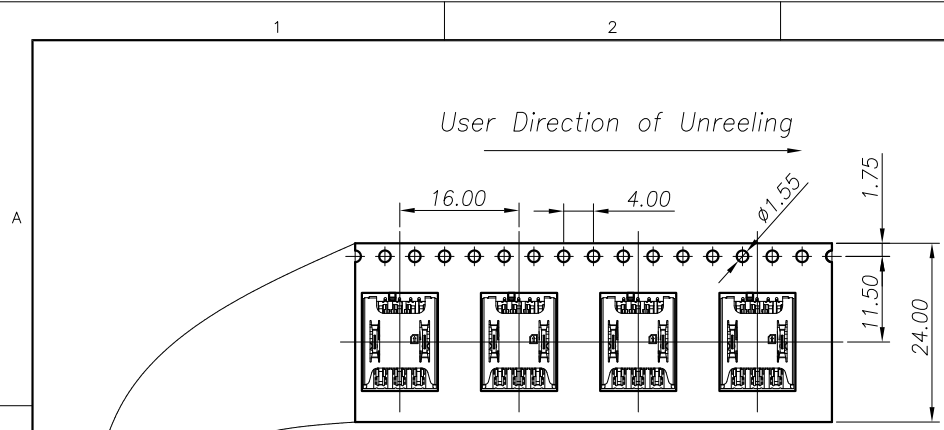

COVER TAPE PEELING ANGLE: 165°~180°  
PEELING FORCE: 20~130g

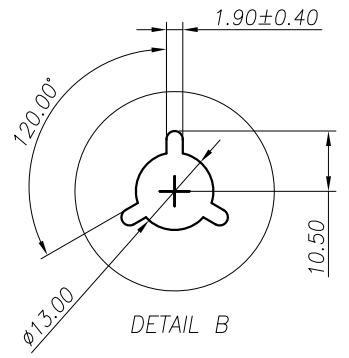
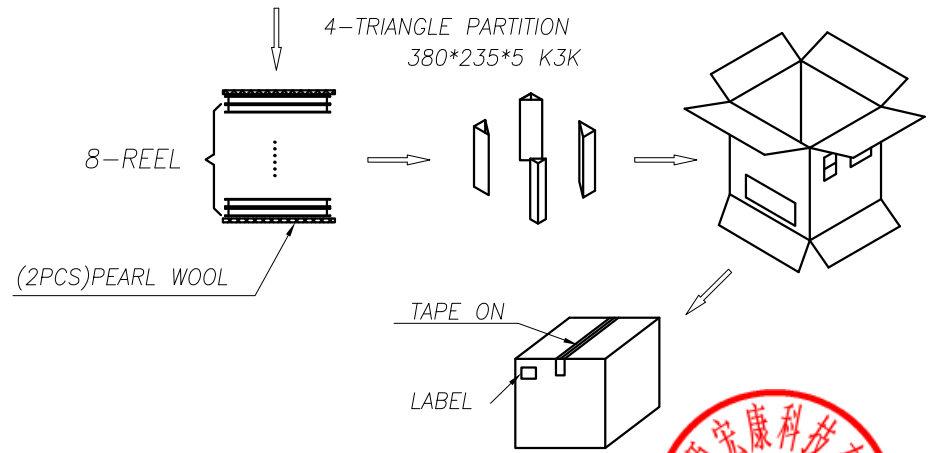
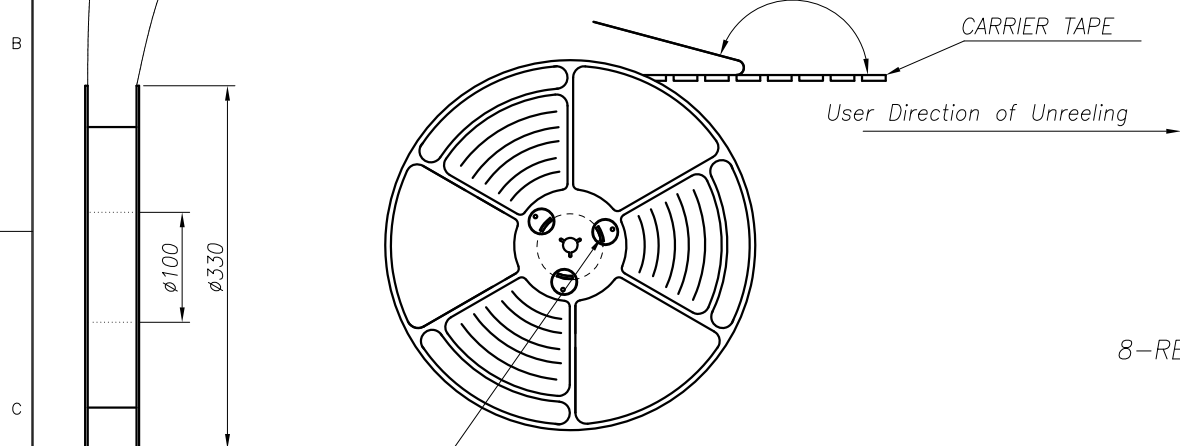

UNLESS OTHERWISE SPECIFIED TOLERANCES		深圳市顺宏康科技有限公司			
DECIMALS:	ANGLES:	TITLE	6Pin 1.4H PUSH-PULL Nano SIM CARD CONN. 包装规范		
X : ±0.5	X : ±2°	DWN	ALLEN	PART NO. SHK-10381	
X.X : ±0.20	X.X : ±1°	CHKD	KEVIN	SCALE: 1:1	UNIT: mm
X.XX : ±0.10		APVD	ERIC.W	SIZE: A3	SHEET: 10F 1
		REV: A2			
CUSTOMER COPY					

