

REV.	ECN NO OR DESCRIPTION	REVISED	DATE
▽	PROPOSE ONLY	ALLEN	2015.06.04

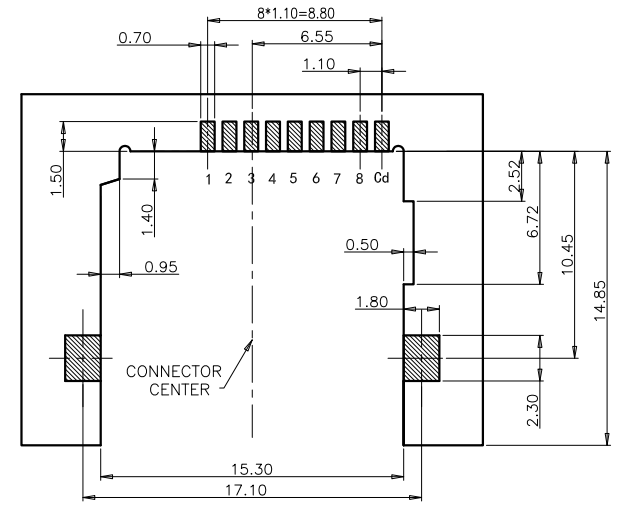
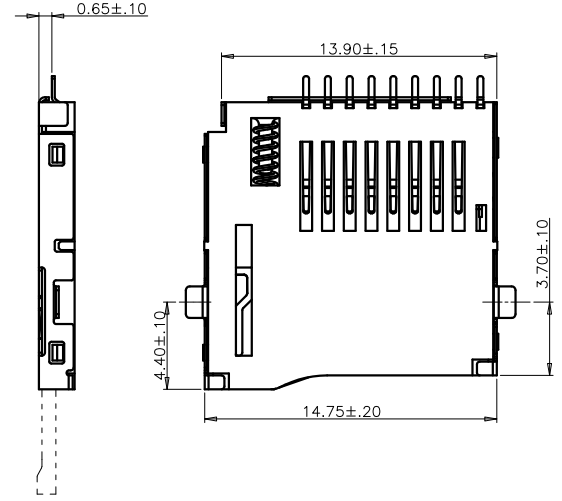
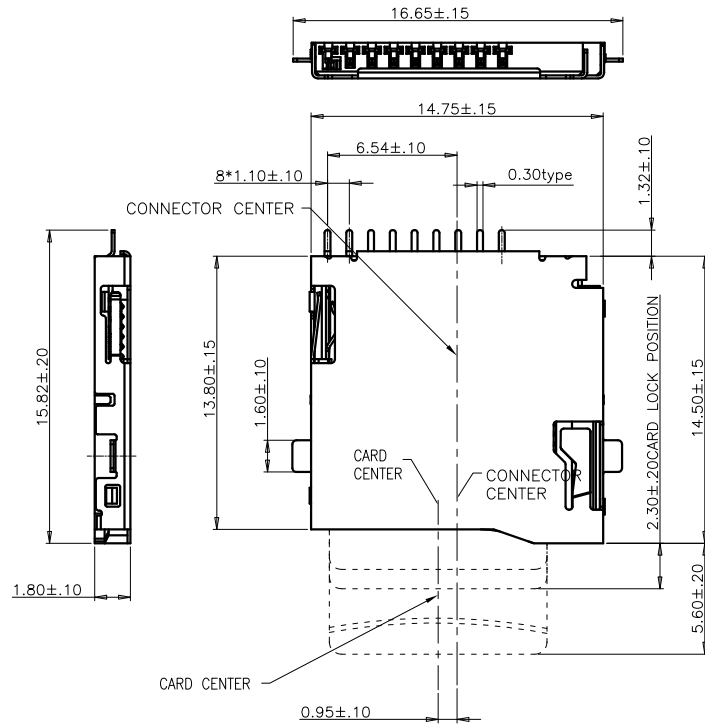

RECOMMENDED PCB LAYOUT  
(TOLERANCE: ±0.05)

Connector Pin Assignment

PIN NO.	NAME	TYPE	DESCRIPTION
1	DAT2	I/O/PP	DATE LINE(BIT2)
2	CD/DAT3	I/O/PP	CARD DETECT DATE LIN(BIT3)
3	CMD	PP	COMMAND RESPONSE
4	VDD	S	SUPPLY VOLTAGE
5	CLX	I	CLOCK
6	VSS	S	SUPPLY VOLTAGE GROUND
7	DAT0	I/O/PP	DATE LINE(BIT0)
8	DAT1	I/O/PP	DATE LINE(DIT1)

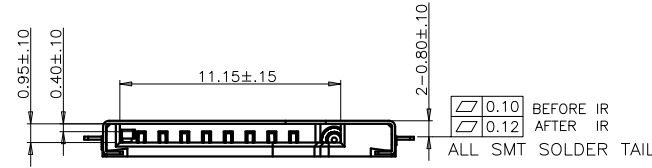
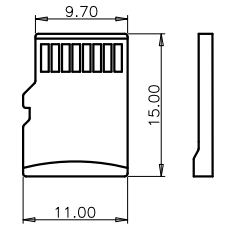

- NOTES:
- ELECTRICAL CHARACTERISTICS  
CONTACT CURRENT RATING:0.5A  
DIELECTRIC WITHSTANDING VOLTAGE:AC 500V  
INSULATION RESISTANCE:500MΩ MIN  
CONTACT RESISTANCE:100mΩ MAX
  - ENVIRONMENTAL  
TEMPERATURE RANGE: -25°C TO +85°C  
MECHANICAL CHARACTERISTICS  
MATING CYCLES:5000 INSERTIONS  
INSERTION/OUT FORCE:0.1-4.0KGF
  - MATERIAL  
INSULATOR: HIGH TEMPERATURE PLASTIC UL94V-0  
COLOR:BLACK  
CONTACT: COPPER ALLOY  
SHELL: STAINLESS  
SPRING:SWP
  - PLATING:  
CONTACT  
UNDERPLATE: NICKEL 40u".  
CONTACT AREA: GOLD FLASH OVER NICKEL 40u".  
SOLDER AREA: TIN 80u" MIN OVER NICKEL 40u".  
SHELL:PLATE 30u"NICKEL MIN OVER ALL
  - PLEASE CONTACT KRCONN SALES REPRESENTATIVE TO VERIFY PRODUCT DETAILS & AVAILABILITY.

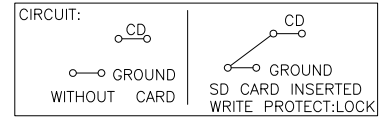
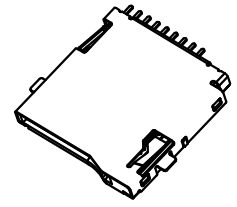

6	SPRING	SUS301-H	1	NO PLATING;
5	CAM FOLLOWER	SUS304-H	1	NO PLATING;
4	SLIDER	SUS301-2/1H+HTN	1	NO PLATING
3	SHELL	SUS301-H	1	Plating Ni 10~50u" over all
2	I/M HSG	PLASTIC	1	BLACK COLOR, UL94 V-0
1	CONTACT	COPPER ALLOY		Plating 50u" ~200u" Ni over all, Plating 1u" Min. Au at contact area;

ITEM	PART NAME	MATERIAL	Q'TY	DESCRIPTION
UNLESS OTHERWISE SPECIFIED TOLERANCES				
DECIMALS:	ANGLES:	TITLE 1.85H PUSH Micro SD(TF) CARD CONN.		
X :±0.5	X :±2°	DWN	ALLEN	PART NO. TOPP-100208-01GB
X.X :±0.20	X.X :±1°	CHKD	KEVIN	SCALE:1:1 UNIT: mm
X.XX :±0.10		APVD	ERIC.W	SIZE: A3 SHEET:10F 1 REV: A2
CUSTOMER COPY				



REV.	ECN NO OR DESCRIPTION	REVISED	DATE
▽	PROPOSE ONLY	ALLEN	2015.06.04

NOTES

- 每卷包装数量:1000PCS/每卷
- 卷带包装方式:
- 每箱包装数量:10000PCS/箱
- 纸箱350mm\*350mm\*340mm(内部尺寸),材质K=K
- 1.0K/箱产品净重: 5.496kg, 毛重: 10.73kg

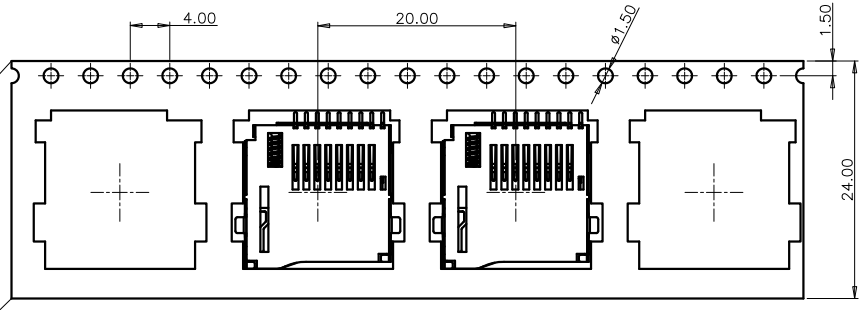

USER DIRECTION OF FEEDING  
客户拉出方向

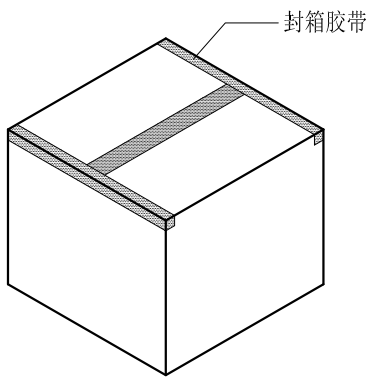
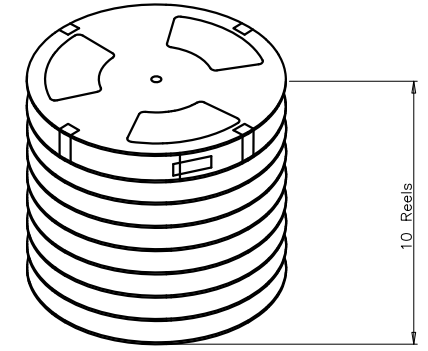
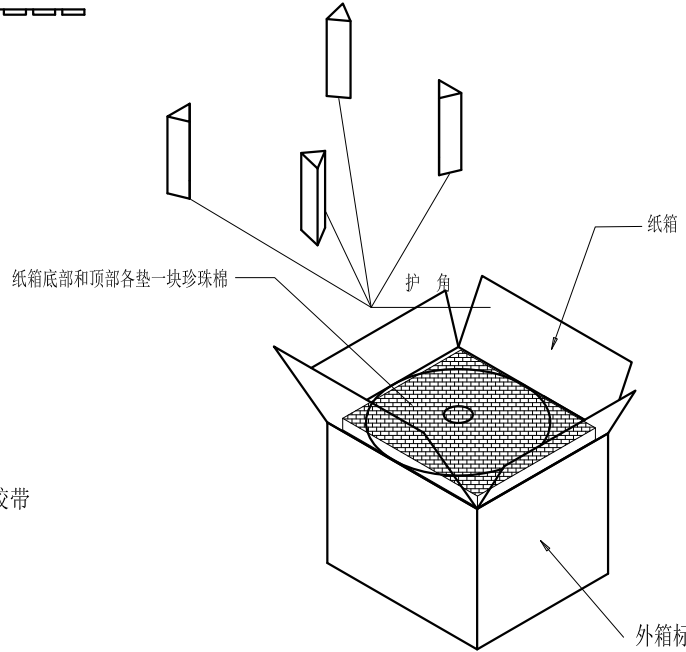
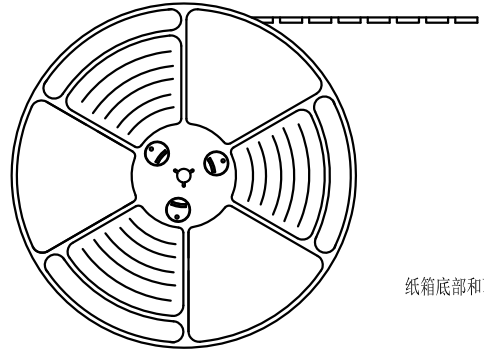

将10卷产品放入箱内

UNLESS OTHERWISE SPECIFIED TOLERANCES					
DECIMALS:	ANGLES:	TITLE	1.85H PUSH Micro SD(TF) CARD CONN.		
X :±0.5	X :±2°	DWN	ALLEN	PART NO. TOPP-100208-01GB	
X.X :±0.20	X.X :±1°	CHKD	KEVIN	SCALE:1:1	UNIT: mm
X.XX :±0.10		APVD	ERIC.W	SIZE: A3	SHEET:10F 1
		REV: A2			
CUSTOMER COPY					