

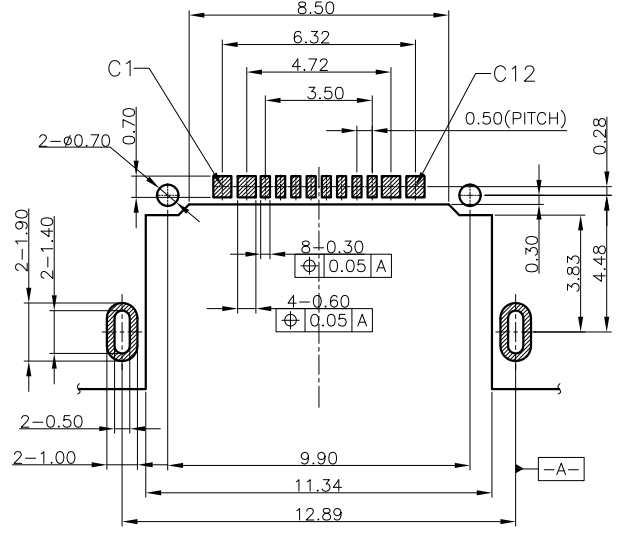

REV.	ECN NO OR DESCRIPTION	REVISED	DATE
A	PROPOSE ONLY	ERIC	2018.03.12

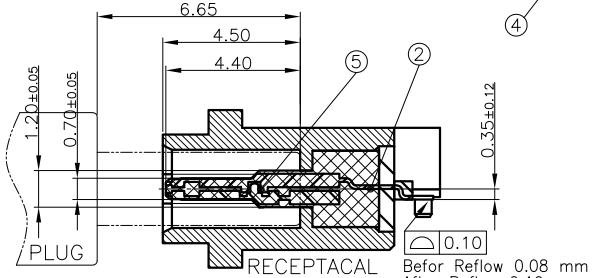

RECOMMENDED P.C.B LAYOUT (COMPONENT SIDE)
 PCB THICKNESS: 0.80±0.05mm
 DEFAULT TOLERANCE: ±0.05mm

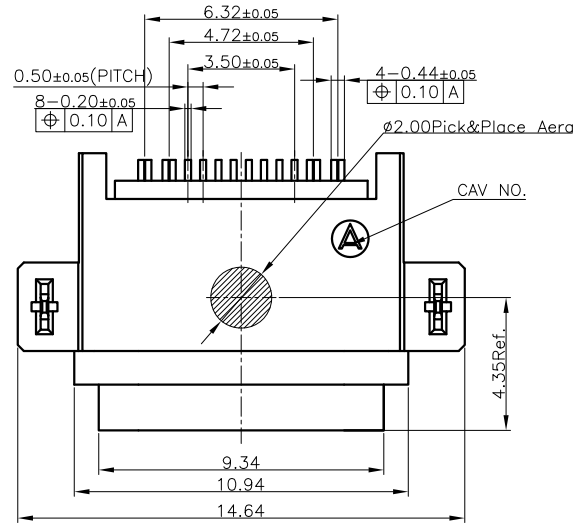
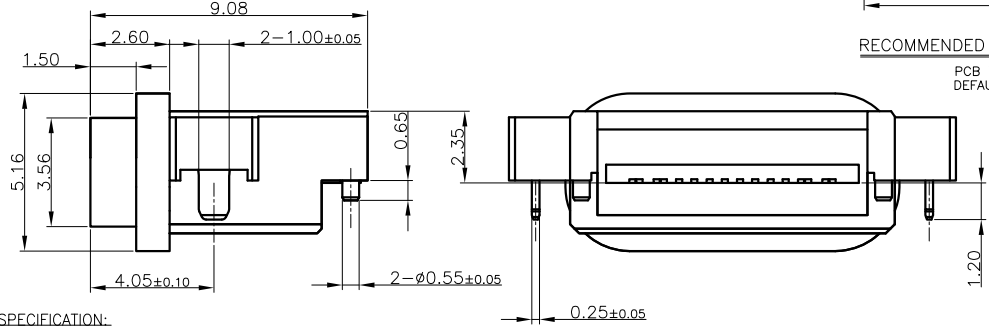
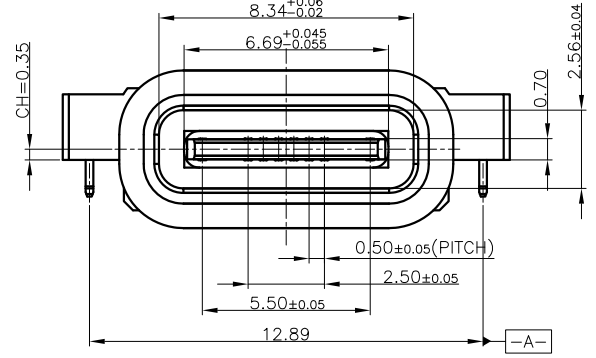

SPECIFICATION:
 1.ELECTRICAL CHARACTERISTICS:
 1.1 CURRENT RATING: 5A
 1.2 CONTACT RATED VOLTAGE:30V AC
 1.3 TEMPERATURE RANGE: -40 °C ~ 85 °C
 1.4 CONTACT RESISTANCE: 40 MILLIONHM MAX.
 1.5 DIELECTRIC WITHSTANDING VOLTAGE: 100 VAC r.m.s
 1.6 INSULATION RESISTNACE: 100 MEGOHMS MIN.
 2.MECHANICAL CHARACTERISTICS
 2.1 INSERTION FORCE: 5~20N
 2.2 EXTRACTION FORCE: Initial:8~20N;
 Durability:6~20N(10000cycles);
 2.3 DURABILITY:10,000CYCLES
 3.2. IR REFLOW:
 THE PEAK TEMPERATURE ON THE BOARD SHALL
 BE MAINTAINED FOR 10 SECONDS AT 260°C.

4.PART NO.: TW R 03-241116 02-11
 TC=TYPE.C WATERPROOF
 R=RECEPTACLE
 Product Order
 24:HEIGHT ON BOARD 2.4mm
 1=BLACK HOUSING
 1=WITH POST
 11= Services NO.
 02=3u" Au Plating
 On Contact Aera
 Pin NO. 16=16Pin

⑤	MID PLATE	1	STAINLESS STEEL	Ni Plating
④	Dip Tail	1	STAINLESS STEEL	Ni Plating
③	Shell	1	PA9T (G.F30%)	Black
②	Contact	5	Phosphor bronze C5191R-EH T=0.12mm	Au/Ni Plating
①	Housing	1	LCP (G.F30%)	Black
ITEM	PART NAME	Q'TY	FINISH	NOTE

UNLESS OTHERWISE SPECIFIED TOLERANCES					
DECIMALS:	ANGLES:	TITLE	Type.C 16Pin Dull SMT CONN. WATERPROOF IPX7		
X :±0.5	X :±2°	DWN	chenjun	PART NO. TWR03-24111602-11	
X.X :±0.30	X.X :±1°	CHKD	chenjun	SCALE:1:1	UNIT: mm
X.XX :±0.20		APVD	Kevin.d	SIZE: A4	SHEET:1OF1
X.XXX :±0.10				REV: A	
			DRAW NO. C-DWG-TWR03-01	CUSTOMER COPY	

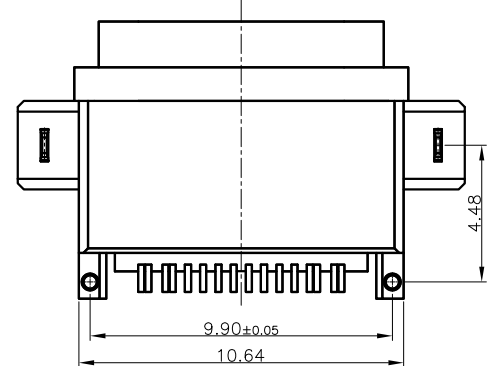



REV.	ECN NO OR DESCRIPTION	REVISED	DATE
A	PROPOSE ONLY	ERIC	2018.03.12

RECOMMENDED OPENING DIMENSIONS
OF CASE MATING AREA WITH
SEALING RING

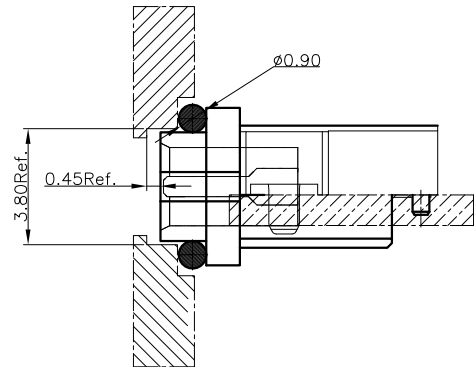

组装示意图

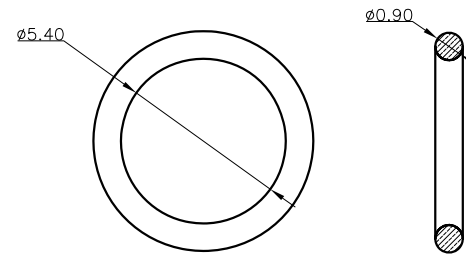

注：防水圈是圆形截面，直径为0.9mm的硅胶圈，防水圈挤压量，由0.9mm 挤压到0.4mm ~ 0.5mm，防水效果好

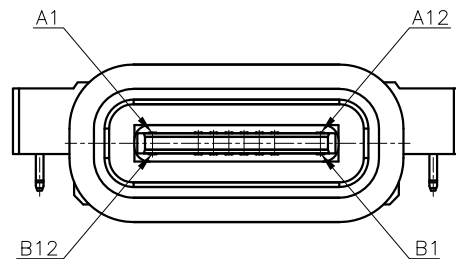

INTERFACE(FRONT VIEW)

A1	A2	A3	A4	A5	A6	A7	A8	A9	A10	A11	A12
GND			VBUS	CC1	DP1	DN1	SBU1	VBUS			GND
GND			VBUS	SBU2	DN2	DP2	CC2	VBUS			GND
B12	B11	B10	B9	B8	B7	B6	B5	B4	B3	B2	B1

PIN ASSIGNMENT

PIN NO.	A1&B12	A4&B9	B8	A5	B7	A6	A7	B6	A8	B5	A9&B4	A12&B1
SINGAL NAME	GND	VBUS	SBU2	CC1	DN2	DP1	DN1	DP2	SBU1	CC2	VBUS	GND
PCB PAD NO.	C1	C2	C3	C4	C5	C6	C7	C8	C9	C10	C11	C12

UNLESS OTHERWISE SPECIFIED TOLERANCES

深圳市顺宏康科技有限公司

DECIMALS:	ANGLES:	TITLE	Type.C 16PIN Dull SMT CONN. WATERPROOF IPX7		
X : ±0.5	X : ±2°	DWN	chenjun	PART NO. TWR03-24111602-11	
X.X : ±0.30	X.X : ±1°	CHKD	chenjun	SCALE:1:1	UNIT: mm
X.XX : ±0.20		APVD	Kevin.d	SIZE: A4	SHEET:1OF1
X.XXX : ±0.10		DRAW NO.	C-DWG-TWR03-01	CUSTOMER COPY	

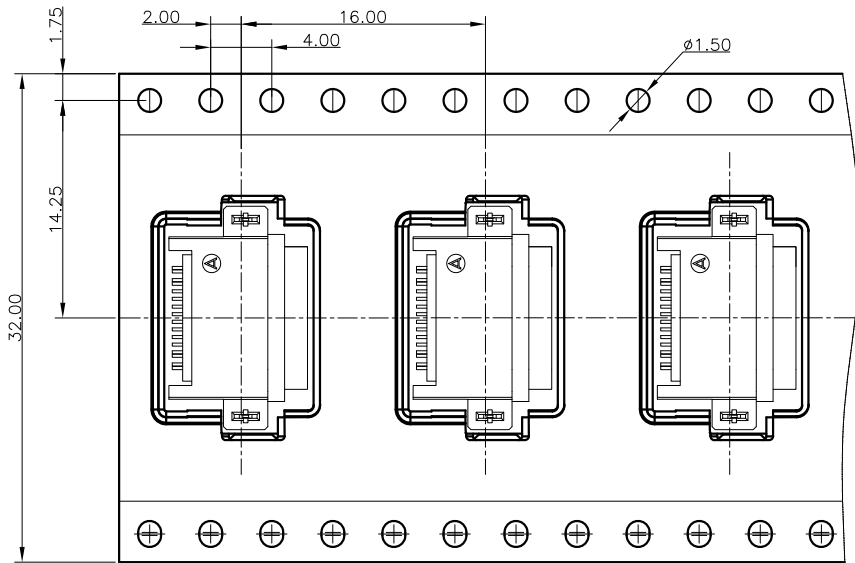
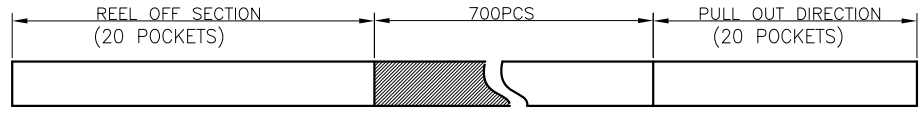

← PRODUCT PACKAGING DIRECTION
 CUSTOMER TO USE DIRECTION →

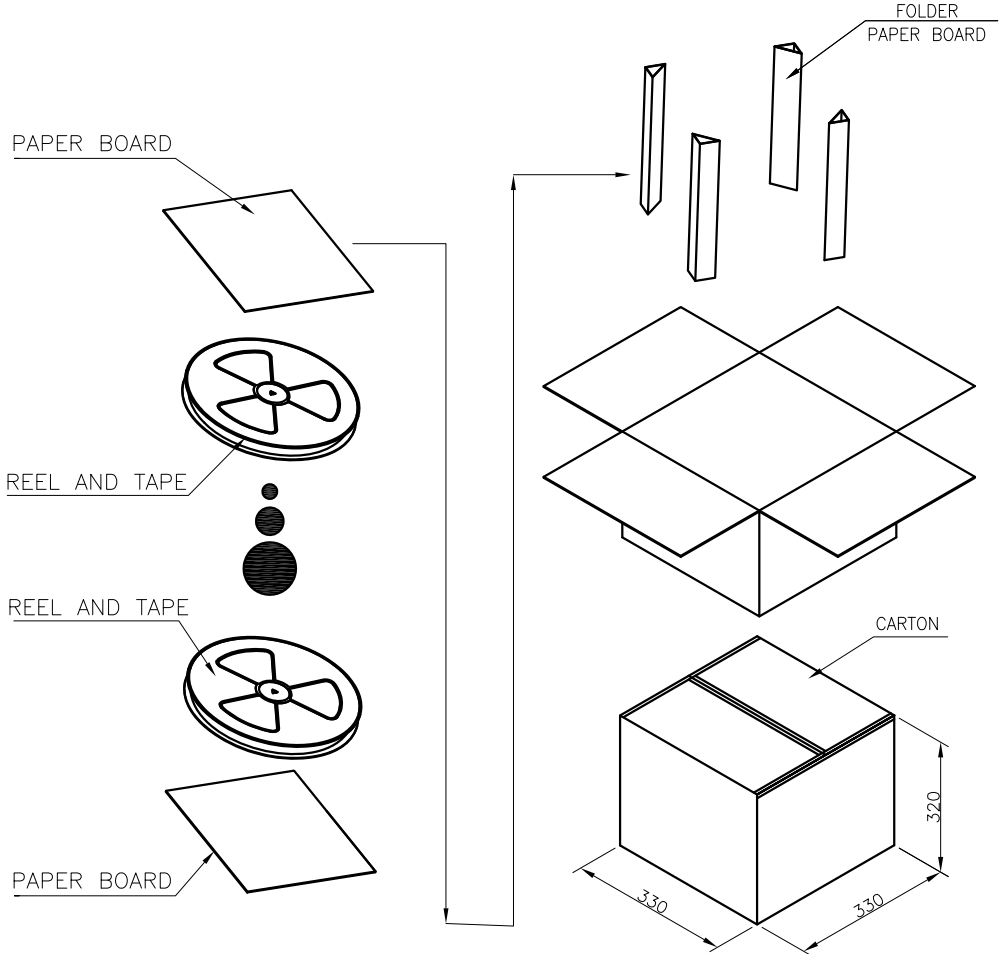
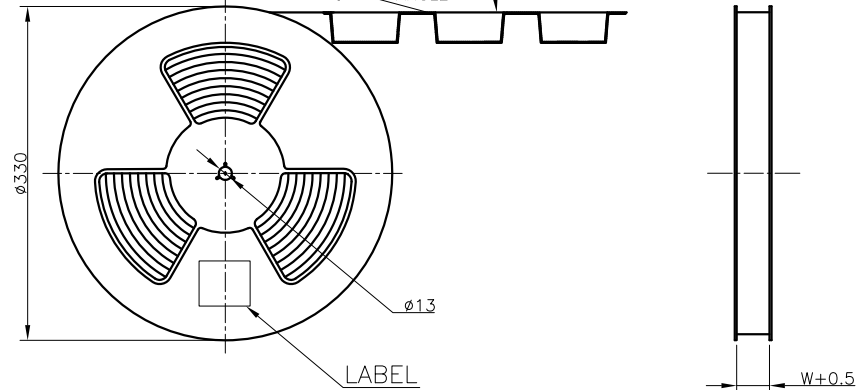

CONN. PART NO.	CONN. QTY./REEL	REEL QTY./CARTON	CONN. QTY./CARTON
TWR03-24111602-11	700	10	7000 PCS

UNLESS OTHERWISE SPECIFIED TOLERANCES

深圳市顺宏康科技有限公司

DECIMALS:	ANGLES:	TITLE	Type.C 10PIN Dull SMT	CONN. WATERPROOF IPX7
X :±0.5	X :±2°	DWN	chenjun	PART NO. TWR03-24111602-11
X.X :±0.30	X.X :±1°	CHKD	chenjun	SCALE:1:1 UNIT: mm
X.XX :±0.20		APVD	Kevin.d	SIZE: A4 SHEET:10F1 REV: A
X XXX :±0.10		DRAW NO.	C-DWG-TWR03-01	CUSTOMER COPY