

REV	LTR	DESCRIPTION	DATE	APPROVED
A0		依新料号编制原则发行图面	20101118	SEEK

01-1\* \*\* \*\* \*\* \*N\*-027  
1 2 3 4 5 6 7 8 9

- 1: 外壳材质代码: A:黄铜C2680, B:磷铜C5191, D:单光铁, E:双光铁
- 2: 外壳电镀代码: A:镀镍12H, B:镀镍24H, C:镀镍48H, D:镀锌, E:镀锡, F:镀镍锡
- 3: 后壳材质及电镀代码: A:SPCC镀镍, B:SPCC镀镍, C:SPCC镀锡, D:SPCC镀镍锡, E:黄铜镀镍, F:黄铜镀镍锡, G:黄铜镀锡, H:黄铜镀锡
- 4: 中夹片材质及电镀代码: A:SPCC镀镍, B:SPCC镀镍锡, C:SPCC镀锡, D:SPCC镀镍锡, E:黄铜镀镍, F:黄铜镀镍锡, G:黄铜镀锡, H:黄铜镀锡, I:磷铜镀镍, J:磷铜镀锡, K:不锈钢, L:不锈钢镀镍
- 5: 胶芯材质代码: A:PBT, B:ICP
- 6: 胶芯颜色代码: 1:白色, 2:黑色, 3:本色
- 7: 端子材质代码: 1:黄铜C2680, 2:磷铜C5191
- 8: 端子电镀代码: A:半金锡6/F, B:半金锡3u", C:半金锡15u", D:半金锡30u"
- 9: 环保代码: N:非环保, R:ROHS, S:SONY, F:ROHS+无卤

- NOTES:
- MATERIAL SPECIFICATION:
    - HOUSING: THERMOPLASTIC(U194V-0)
    - SHELL: SEE PART NO.
    - PLATING: NICKEL
    - TERMINAL: COPPER ALLOY
  - PLATING: GOLD/TIN PLATED; ELECTRICAL CHARACTERISTIC:
    - VOLTAGE CURRENT RATING: 1AMP, 30V DC;
    - INSULATION RESISTANCE: 1000M Ω MIN;
    - CONTACT RESISTANCE: 30m Ω MAX;
    - WITHSTANDING VOLTAGE: 500V AC;
  - MECHANICAL:
    - MATING FORCE: 3.5 KG MAX
    - UNMATING FORCE: 1.02 KG MIN.

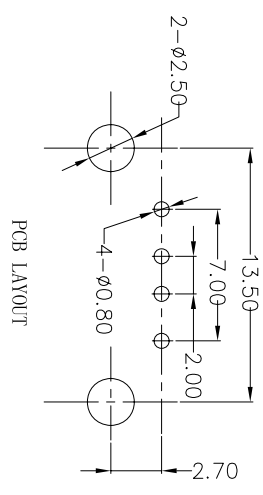
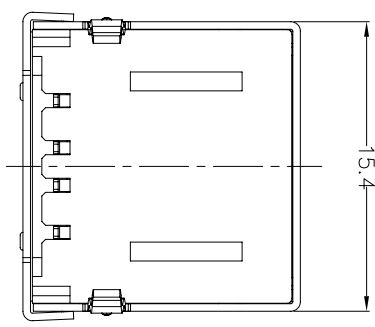
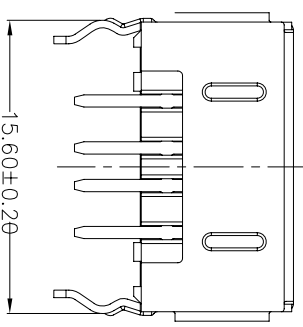
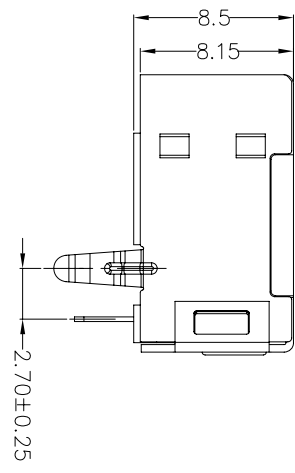
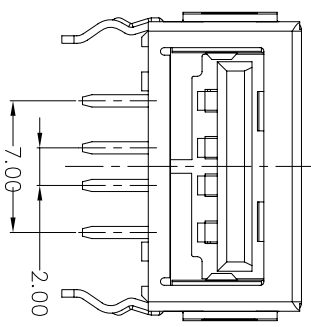
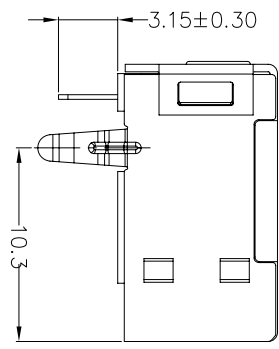
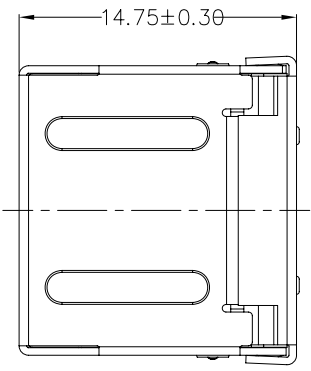

TOLERANCES

.X	±0.30
.XX	±0.20
.XXX	±0.10
ANGLES	±2.00°

深圳市顺宏康科技有限公司

PART NO.: SHK-20101

APPD:					
CHECK:					
DRAWN:	蒋翔	20101118	REV.:	A/0	
DRAWING NO.:	011-027	SIZE:	A4	UNIT:	M M
SCALE:	1:1	SHEET:	1/1		